

adaptalift **GROUP**



# J2.2-3.5XN

2,200 - 3,500 KG

FOUR WHEEL ELECTRIC  
COUNTERBALANCE SERIES



THE SOLUTION TO YOUR  
APPLICATION NEEDS

**13 22 54**

[www.adaptalift.com.au](http://www.adaptalift.com.au)

## OVERVIEW

Designed for both indoor and outdoor use, the Hyster J2.2 – 3.5XN has all the benefits of an internal combustion truck with lower maintenance needs and no exhaust emissions.

## PRODUCT FEATURES

The Hyster J2.2 – 3.5XN series of forklifts features industry leading innovations that deliver what matters most:

Reliability, Dependability and Low cost of ownership

### 1 Overhead Guard

The unique grid-style pattern improves visibility while protecting operators and strengthening the truck's structure. The front, curved OHG leg design affords greater shoulder clearance for easier operator entry and exit.

### 2 Fatigue-Reducing Operator Compartment

Ergonomically designed operator compartment enhances overall productivity. Features include: increased foot space and optimised step height for easy entry and exit; fully adjustable, full suspension seat (optional) with low whole body vibration levels; infinitely adjustable steering column with optional memory tilt and telescopic steering wheel and low effort e-hydraulic controls. The standard non-suspension seat and optional suspension and swivel seats are all easily adjusted to provide a more customised, comfortable ride.

### 3 Multifunction Display

The location of the multifunction display provides maximum forward visibility and ease of operation. The display does not obstruct the forward view of the operator and is within easy reach of the operator, supervisor or service technician for quick access to truck functions, diagnostics and troubleshooting.

### 4 AC Motors

The brushless AC traction and hydraulic motors, powered by transistor controls, are durable enough to handle your toughest duty cycle, with reduced maintenance costs and enhanced productivity.

### 5 "Drop Battery Box"

The battery sits low in the frame resulting in a lower seating position, making entry and exit from the truck easier and maximising truck stability and capacity. The new stamped steel hood is designed for durability and protection.

### 6 "Zero Turn" Steer Axle

Features advanced turning capability to provide superb manoeuvrability during operation.

### 7 Pneumatic Tyres

The pneumatic tyres on the J2.2–3.5XN series reduce vibration to provide a smooth, comfortable ride, even over less than ideal surfaces.

### 8 LED Lights

Bright and long lasting, the optional LED front and rear working lights and brake/tail/back-up lights rarely need replacing. The plastic lens meets the FDA requirement for use in food applications.



**9 Exclusive VISTA® Mast**

High strength hot-rolled steel mast channels and flush-faced design improve capacity retention at high lifts. Compact cast steel cross members optimise visibility and rigidity. Six canted 3-inch full-face load rollers roll on the web and the flange simultaneously, eliminating the need for side thrust rollers or wear plugs.

**10 Hyster Stability Mechanism**

The new stability system reduces truck lean in turns, allowing superior travel over uneven surfaces. The stability system requires no maintenance.

**11 Tilt Steer Column**

The infinitely adjustable tilt steer column with optional telescopic column and tilt memory accommodates all operators easily. Assisted by a gas-spring and an easy-to-reach lever, obtaining your preferred position is simple.

**12 Hassle-Free Hydraulics**

Use of leak-free O-ring face seals helps maximise uptime. In-tank filter increases hydraulic fluid filtration by 60% for particles down to 10 microns, significantly extending component life by creating a cleaner overall operation.

**13 Pacesetter VSM™**

The computer “brain” of these lift trucks manages all vehicle systems to optimise performance, significantly increase overall reliability and enhance diagnostic capability to give maximum uptime.

**14 Removable Floor Plate**

Two-piece steel floor plate and side plates are easily removed to provide instant service access. A thick moulded rubber floor mat seals the floor area to reduce noise and vibration for a more comfortable ride.

**15 Integral Sideshift**

The optional Hyster-designed integral sideshift provides excellent visibility and affords greater capacities than carriage-mounted sideshifts.

**16 Heavy-duty Drive Axle**

The full floating design of the drive axle lets the axle housing, not the shafts, carry the weight of the load, enhancing dependability and reliability for a longer service life. Hyster premium oil-cooled wet disc brakes provide smooth stopping with reduced pedal effort as well as long brake life.



# J2.2-3.5XN

2,200 - 3,500 KG

FOUR WHEEL ELECTRIC  
COUNTERBALANCE  
SERIES



The Hyster J2.2 – 3.5XN series is available in 2 configurations – **Advance & Advance +**.

With enhanced performance characteristics, the Advance+ configuration has been designed to operate in intensive, high productivity applications with long runs and high lifts as an effective alternative to an engine-powered truck.

For example, in comparison to the Advance configuration, top speed (laden) has been increased to up to 21 km/h with faster acceleration, and lifting speeds have been increased by 27%.





## LOWER COST OF OWNERSHIP

Hyster keeps total operating costs low.

- ✓ Customisable performance settings allow energy efficiency to be ideally balanced with productivity delivering high throughput at lower operating cost.
- ✓ The Vehicle System Manager (VSM) allows adjustment of truck performance parameters and monitors key functions, leading to application matched performance and minimum downtime.
- ✓ Durable, quality components, including virtually maintenance free oil immersed brakes and brushless AC motors offer long term reliability and lower maintenance costs.
- ✓ In-built thermal protection on traction motors and advanced cooling system protect truck components, leading to reduced maintenance costs.
- ✓ Fast delivery of diagnostic information allows precise troubleshooting, easy maintenance planning and lower costs.

## DEPENDABILITY

Dependable Performance from Hyster.

- ✓ Robust mast design provides excellent visibility and reliable, high performance lifting.
- ✓ Strong chassis construction and reliable, long-lasting components deliver excellent durability and stability, increasing driver confidence and enhancing productivity.
- ✓ AC motor technology on traction and hoist, with built in thermal management system, allows the truck to work reliably over long runs and in demanding work cycles, reducing downtime significantly.
- ✓ The electrical system features a CANbus communications network and Hall Effect sensors for increased reliability.





# J2.2-3.5XN

2,200 - 3,500 KG

FOUR WHEEL ELECTRIC  
COUNTERBALANCE  
SERIES

## ENHANCED PRODUCTIVITY & SUPERIOR ERGONOMICS

Dual 10 kW AC front wheel traction motors deliver smooth acceleration, fast travel and rapid direction changes. This is combined with regenerative braking and a powerful hoist motor to deliver efficient load handling in the toughest of applications.

### Productivity

- ✔ Designed to offer excellent manoeuvrability in working aisles, speeding up throughput, the forklift features a slim counterweight, Zero Turn Radius (ZTR) steer axle and dual drive motors.
- ✔ The maintenance-free mechanical Hyster Stability Mechanism (HSM) reduces truck lean when travelling over obstacles, increasing driver confidence and productivity.
- ✔ Extended battery shift life and easy side battery removal systems offer increased uptime with a fast, simple recharging process to keep trucks on the move.

### Ergonomics

- ✔ The ergonomically designed operator compartment provides a comfortable and highly productive environment for the driver. The truck offers industry leading floor space and easy on/off access is enhanced thanks to the low intermediate non-slip step (height = 475 mm).
- ✔ Low noise and whole body vibration combined with a new full suspension seat with 80mm suspension travel and a range of adjustments ensures the operator remains comfortable over long shifts.
- ✔ The fully adjustable tilt steering column with telescopic adjustment, memory tilt and synchronised steering options allows the operator to get on and off the truck quickly and easily throughout the shift, ensuring maximum comfort and increased productivity.
- ✔ The new mini-lever module armrest with built in hydraulic controls, integrated directional control, emergency off switch and horn offers the ultimate in comfort and control. Alternatively, seat-side manual levers also provide handling ease.
- ✔ A 'Heads-up' display keeps the driver's field of vision clear but provides him with 'at a glance' information on truck operating conditions or performance settings.
- ✔ A choice of weather protection options promotes a comfortable working environment, whatever the conditions.





## **SIMPLIFIED SERVICE**

Comprehensive support is provided by the extensive and experienced Hyster dealer network.

### **Superior Serviceability**

- ✓ Standard 1,000 hour service interval.
- ✓ Access to diagnostic information via the display or plug-in point on the steering column allows service technicians to monitor truck operations and plan maintenance requirements.
- ✓ Easily removable two-piece floor plate provides easy access to power contactor, traction controller fuses and relays.
- ✓ Motor, pump, controller and oil tank are located in the counterweight and are easily accessible, requiring only 2 thumb screws to be removed.
- ✓ Automatic park brake system can be released manually by activating lever arrangement underneath floor plates, reducing downtime.
- ✓ LED work lights are designed to last the lifetime of the truck.





# TECHNICAL SPECIFICATIONS

## CHARACTERISTICS

CHARACTERISTICS		ADVANCE							
1.1	Manufacturer	Hyster		Hyster		Hyster		Hyster	
1.2	Model Description	J2.2XN		J2.5XN (717)		J2.5XN (861)		J3.0XN	
1.3	Power: Battery, Diesel, LPG, Electric Mains	Battery		Battery		Battery		Battery	
1.4	Operation: Manual, Pedestrian, Stand, Seat, Orderpicker	Seat		Seat		Seat		Seat	
1.5	Load Capacity	Q (kg)	2200	2500	2500	2500	3000	3000	3000
1.6	Load Centre	c (mm)	500	500	500	500	500	500	500
1.8	Load Distance	x (mm)	404	404	404	404	416	416	416
1.9	Wheelbase	y (mm)	1606	1606	1606	1750	1750	1750	1750

## WEIGHT

2.1	Unladen Weight (max. battery)	kg	4465	4465	4465	4876	4910	4910	4910	
2.2	Axle Loading, with load front/rear (max. battery)	kg	5651	1014	6120	845	6195	1181	7006	904
2.3	Axle Loading without load front/rear (max. battery)	kg	2212	2253	2212	2253	2403	2473	2443	2467

## WHEELS & TYRES

3.1	Tyres: L=Pneumatic, V=Cushion, SE=Pneumatic Shaped Solid	SE		SE		SE		SE		
3.2	Tyre Size, front	23 x 10 - 12		23 x 10 - 12		23 x 10 - 12		23 x 10 - 12		
3.3	Tyre Size, rear	18 x 7 - 8		18 x 7 - 8		18 x 7 - 8		18 x 7 - 8		
3.5	Number of Wheels, front/rear (x = driven)	2x	2	2x	2	2x	2	2x	2	
3.6	Track Width, front, standard/wide tread	b10 (mm)	938	1054	938	1054	938	1054	938	1054
3.7	Tread Width, rear	b11 (mm)	992	992	992	992	992	992	992	

## DIMENSIONS

4.1	Mast Tilt, a = Forwards/ b = Back	degrees	5	5	5	5	5	5	5	5	
4.2	Height of Mast, Lowered ❖	h1 (mm)	2192	2192	2192	2192	2192	2192	2192	2192	
4.3	Free Lift	h2 (mm)	100	100	100	100	100	100	100	100	
4.4	Lift Height	h3 (mm)	3350	3350	3350	3350	3350	3350	3155	3155	
4.5	Height of Mast, extended	h4 (mm)	3960	3960	3960	3960	3960	3960	3865	3865	
4.7	Overhead Guard Height	h6 (mm)	2193	2193	2193	2193	2193	2193	2193	2193	
4.8	Seat Height	h7 (mm)	1069	1069	1069	1069	1069	1069	1069	1069	
4.12	Towing Coupling Height	h10 (mm)	262	262	262	262	262	262	262	262	
4.19	Overall length	l1 (mm)	3321	3321	3321	3465	3465	3465	3465	3465	
4.20	Length to Face of Forks	l2 (mm)	2321	2321	2321	2465	2465	2465	2465	2465	
4.21	Overall Width (standard/ wide tread)	b1/b2 (mm)	1173	1289	1173	1289	1173	1289	1173	1289	
4.22	Fork Dimensions	s/e/l (mm)	40	100	1000	40	100	1000	45	100	1000
4.23	Fork Carriage DIN 15173. Class A/B		2A	2A	2A	2A	2A	2A	3A	3A	
4.24	Fork Carriage width	b3 (mm)	1067	1067	1067	1067	1067	1067	1067	1067	
4.31	Ground Clearance under mast, with load	m1 (mm)	98	98	98	98	98	98	98	98	
4.32	Ground Clearance, centre of wheelbase	m2 (mm)	137	137	137	137	137	137	137	137	
4.33	Aisle width with pallets 1000mm long x 1200mm wide	Ast (mm)	3598	3598	3598	3736	3736	3736	3747	3747	
4.34	Aisle width with pallets 800mm wide x 1200mm long	Ast (mm)	3751	3751	3751	3891	3891	3891	3903	3903	
4.35	Outer Turning Radius	Wa (mm)	1931	1931	1931	2073	2073	2073	2073	2073	
4.36	Inner Turning Radius	b13 (mm)	173	173	173	189	189	189	189	189	

## PERFORMANCE

5.1	Travel Speed with/without load	km/h	18,0	18,0	18,0	18,0	18,0	18,0	17,0	18,0
5.2	Lifting Speed with/without load	m/sec	0,40	0,63	0,38	0,63	0,38	0,63	0,33	0,59
5.3	Lowering Speed with/without load	m/sec	0,57	0,51	0,57	0,51	0,57	0,51	0,56	0,46
5.5	Drawbar pull with/without load, 60 minute rating	N	5468	5773	5591	5726	5591	5726	5441	5588
5.6	Max. Drawbar pull with/without load, 5 minute rating	N	18045	19052	18451	18897	18451	18897	17956	18441
5.7	Gradeability with/without load, 30 minute rating	%	10	14	9	13	9	13	8	12
5.8	Maximum Gradeability with/without load, 5 minute rating	%	26	39	24	35	24	35	22	34
5.9	Acceleration time with/without load	Sec	4,42	4,11	4,45	4,11	4,45	4,11	4,56	4,18
5.10	Service Brake		Hydraulic	Hydraulic	Hydraulic	Hydraulic	Hydraulic	Hydraulic	Hydraulic	Hydraulic

## MOTOR

6.1	Drive Motor Rating, S2, 60min	kW	2x 10,0	2x 10,0	2x 10,0	2x 10,0	2x 10,0	2x 10,0	2x 10,0	
6.2	Lifting Motor, S3 15% Rating	kW	16,0	16,0	16,0	16,0	16,0	16,0	16,0	
6.3	Battery DIN 43531/35/36 A,B,C, no		DIN 43536 A	DIN 43536 A	DIN 43536 A	DIN 43536 A	DIN 43536 A	DIN 43536 A	DIN 43536 A	
6.4	Battery Voltage/Capacity at 5 hour rate	V/Ah	80	560	80	560	80	700	80	700
6.5	Battery Weight (min/max)	kg	1480	1635	1480	1635	1770	1956	1770	1956
6.6	Power Consumption in accordance with VDI cycle	kWh/h	6,68	7,00	6,68	7,00	7,89	8,66	7,89	8,66

## OTHER

8.1	Drive Control		AC electronic	AC electronic	AC electronic	AC electronic	AC electronic	AC electronic	AC electronic
8.2	Operating pressure for attachments	bar	155	155	155	155	155	155	155
8.3	Oil flow for attachments	l/min	20-40	20-40	20-40	20-40	20-40	20-40	20-40
8.4	Average Noise level at Operator's ear	dB (A)	67	67	67	67	67	67	67
8.5	Towing Coupling type		Pin	Pin	Pin	Pin	Pin	Pin	Pin

## Equipment and Weight

Weights (line 2.1) are based on the following specifications: Complete truck with 3 320 mm Vista Plus (J1.5-1.6XN) or 3 390 mm Vista (J1.8-2.0XN) 2- stage limited free lift mast, 910 mm hook type carriage with load backrest and 1 000 mm forks. Overhead guard and pneumatic shaped solid drive and steer tyres.



Hyster
J3.5XN
Battery
Seat
3500
500
416
1750

### ADVANCE +

1.1	Hyster	Hyster	Hyster	Hyster	Hyster
1.2	J2.2XN	J2.5 XN (717)	J2.5XN (861)	J3.0XN	J3.5 XN
1.3	Battery	Battery	Battery	Battery	Battery
1.4	Seat	Seat	Seat	Seat	Seat
1.5	2200	2500	2500	3000	3500
1.6	500	500	500	500	500
1.8	404	404	404	416	416
1.9	1606	1606	1750	1750	1750

5225	
7714	1011
2391	2834

### WEIGHT

2.1	4465	4465	4876	4910	5225					
2.2	5651	1014	6120	845	6195	1181	7006	904	7714	1011
2.3	2212	2253	2212	2253	2403	2473	2443	2467	2391	2834

SE	
23 x 10 - 12	
18 x 7 - 8	
2x	2
938	1054
992	

### WHEELS & TYRES

3.1	SE	SE	SE	SE	SE					
3.2	23 x 10 - 12	23 x 10 - 12	23 x 10 - 12	23 x 10 - 12	23 x 10 - 12					
3.3	18 x 7 - 8	18 x 7 - 8	18 x 7 - 8	18 x 7 - 8	18 x 7 - 8					
3.5	2x	2	2x	2	2x	2				
3.6	938	1054	938	1054	938	1054	938	1054	938	1054
3.7	992	992	992	992	992	992				

5	5	
2192		
100		
3155		
3865		
2193		
1069		
262		
3555		
2555		
1173	1289	
45	100	1000
3A		
1067		
98		
137		
3813		
3969		
2139		
189		

### DIMENSIONS

4.1	5	5	5	5	5	5	5	5	5	5	5				
4.2	2192		2192		2192		2192		2192		2192				
4.3	100		100		100		100		100		100				
4.4	3350		3350		3350		3155		3155		3155				
4.5	3960		3960		3960		3865		3865		3865				
4.7	2193		2193		2193		2193		2193		2193				
4.8	1069		1069		1069		1069		1069		1069				
4.12	262		262		262		262		262		262				
4.19	3321		3321		3465		3465		3555		3555				
4.20	2321		2321		2465		2465		2555		2555				
4.21	1173	1289	1173	1289	1173	1289	1173	1289	1173	1289	1173	1289			
4.22	40	100	1000	40	100	1000	40	100	1000	45	100	1000	45	100	1000
4.23	2A		2A		2A		3A		3A		3A				
4.24	1067		1067		1067		1067		1067		1067				
4.31	98		98		98		98		98		98				
4.32	137		137		137		137		137		137				
4.33	3598		3598		3736		3747		3813		3813				
4.34	3751		3751		3891		3903		3969		3969				
4.35	1931		1931		2073		2073		2139		2139				
4.36	173		173		189		189		189		189				

16,0	18,0
0,31	0,59
0,58	0,46
5478	5720
18076	18875
7	12
20	32
4,60	4,23
Hydraulic	

### PERFORMANCE

5.1	21,0	21,0	21,0	21,0	19,5	21,0	18,0	21,0		
5.2	0,52	0,72	0,49	0,72	0,49	0,72	0,42	0,63	0,37	0,63
5.3	0,57	0,51	0,57	0,51	0,57	0,51	0,56	0,46	0,58	0,46
5.5	6015	6235	6037	6185	6037	6185	5877	6035	5918	6177
5.6	19849	20576	19927	20409	19927	20409	19393	19916	19522	20385
5.7	11	16	10	14	10	14	9	13	8	13
5.8	28	42	26	38	26	38	24	37	22	35
5.9	4,04	3,71	4,04	3,71	4,04	3,71	4,14	3,78	4,19	3,83
5.10	Hydraulic		Hydraulic		Hydraulic		Hydraulic		Hydraulic	

2x 10,0	
16,0	
DIN 43536 A	
80	700
1770	1956
10,03	

### MOTOR

6.1	2x 10,0	2x 10,0	2x 10,0	2x 10,0	2x 10,0					
6.2	24,0	24,0	24,0	24,0	24,0					
6.3	DIN 43536 A	DIN 43536 A	DIN 43536 A	DIN 43536 A	DIN 43536 A					
6.4	80	560	80	560	80	700	80	700	80	700
6.5	1480	1635	1480	1635	1770	1956	1770	1956	1770	1956
6.6	7,51	7,87	8,86	9,74	11,28					

AC electronic
155
20-40
67
Pin

### OTHER

8.1	AC electronic	AC electronic	AC electronic	AC electronic	AC electronic
8.2	155	155	155	155	155
8.3	20-40	20-40	20-40	20-40	20-40
8.4	68	68	68	68	68
8.5	Pin	Pin	Pin	Pin	Pin

# TRUCK DIMENSIONS

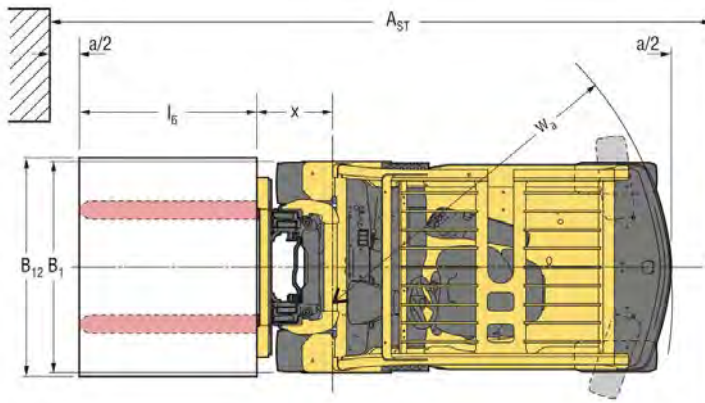
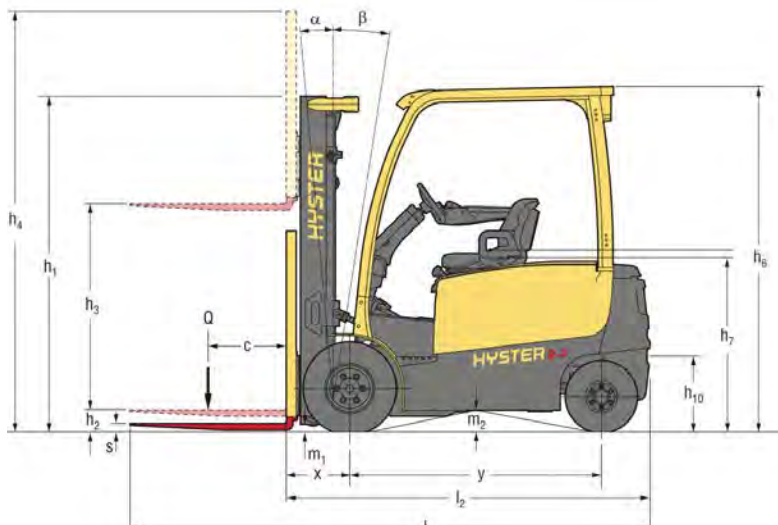











 = Centre of gravity of unladen truck

$$A_{st} = W_a + R + a \text{ (see lines 4.33 and 4.34)}$$







$$R = \sqrt{(l_6 + x)^2 + (b_{12} - b_{13})^2}$$

## Note:

Specifications are affected by the condition of the vehicle and how it is equipped, as well as the nature and condition of the operating area. If these specifications are critical, the proposed application should be discussed with your **Adaptalift Hyster** dealer.

-  Bottom of forks
-  Without load backrest
-  Full suspension seat (FLM80) specified. Compressed condition, add 40 mm for nominal position. Add 104 mm for battery side removal option
-  Add 28 mm with load backrest
-   $h_6$  subject to +/- 5 mm tolerance. Add 104 mm for battery side removal option
-  Stacking aisle width (lines 4.33 & 4.34) is based on the V.D.I. standard calculation as shown on illustration. The British Industrial Truck Association recommends the addition of 100 mm to the total clearance (dimension a) for extra operating margin at the rear of the truck.
-  Gradeability figures (lines 5.7 & 5.8) are provided for comparison of tractive performance, but are not intended to endorse the operation of the vehicle on the stated inclines. Follow instructions in the operating manual regarding operation on inclines.
-  Variable
-  Advance configuration, with eLo performance setting
-  Advance+ configuration with HiP performance setting
-  Lpaz, measured according to the test cycles and based on the weighting values contained in EN12053

## Tables key:

-  Add 666 mm with load backrest extension
-  Deduct 666 mm with load backrest extension
-  Add 684 mm with load backrest extension
-  Deduct 684 mm with load backrest extension
-  Add 583 mm with load backrest extension
-  Deduct 583 mm with load backrest extension
-  Add 601 mm with load backrest extension
-  Deduct 601 mm with load backrest extension
-  Wide tread required. Standard tread possible but with reduced capacity. Contact your **Adaptalift Hyster** Dealer.

## Notice

Care must be exercised when handling elevated loads. When the carriage and/or load is elevated, truck stability is reduced. It is important that mast tilt in either direction be kept to a minimum when loads are elevated. Operators must be trained and adhere to the instructions contained in the Operating Manual.

Hyster products are subject to change without notice. Forklifts illustrated may feature optional equipment.

## Safety:

This truck conforms to the current EU requirements and Australian ISO Standards.



# MAST AND CAPACITY

## Mast and Capacity Information

	Maximum fork height mm (h3+s)	Back Tilt	Overall lowered height mm	Overall extended height mm	Free lift (top of forks) mm (h2+s)
<b>Vista Masts J2.2 – 2.5XN</b>					
Vista 2 Stage	3390	5°	2195	3956	140
limited free lift	3790	5°	2395	4356	140
	4330	5°	2745	4896	140
	4830	5°	2995	5396	140
Vista 2 Stage	3400	5°	2195	3966	1625
full free lift	3800	5°	2395	4366	1825
	4420	5°	2745	4986	2175
Vista 3 Stage	4950	5°	2145	5496	1595
full free lift	5550	5°	2395	6096	1845
	6000	5°	2595	6546	2045
<b>Vista Masts J3.0 – 3.5XN</b>					
Vista 2 Stage	3200	5°	2195	3861	145
limited free lift	3600	5°	2395	4261	145
	4100	5°	2745	4761	145
	4600	5°	2990	5261	145
Vista 2 Stage	3205	5°	2195	3862	1535
full free lift	3905	5°	2595	4562	1935
	4405	5°	2845	5062	2185
Vista 3 Stage	4610	5°	2145	5252	1500
full free lift	4910	5°	2295	5552	1650
	5210	5°	2395	5852	1750
	5810	5°	2645	6452	2000

## J2.2 – 3.5XN - Capacity Chart in kg @ 500mm Load Centre - Pneumatic Shaped Solid Tyres

	Maximum fork height mm (h3+s)	Without Sideshift			With Integral Sideshift			Maximum fork height mm (h3+s)	Without Sideshift		With Integral Sideshift	
		J2.2XN (717)	J2.5XN (717)	J2.5XN (861)	J2.2XN (717)	J2.5XN (717)	J2.5XN (861)		J3.0XN (861)	J3.5XN (861)	J3.0XN (861)	J3.5XN (861)
Vista 2 Stage	3390	2200	2500	2500	2200	2490	2500	3200	3000	3500	2960	3440
limited free lift	3790	2200	2500	2500	2200	2490	2500	3600	3000	3500	2950	3430
	4330	2200	2500	2500	2200	2470	2500	4100	3000	3500	2940	3420
	4830	2200	2480	2500	2190	2440	2500	4600	2920	3410	2850	3330
Vista 2 Stage	3400	2200	2500	2500	2200	2500	2500	3205	3000	3500	2960	3440
full free lift	3800	2200	2500	2500	2200	2490	2500	3905	3000	3500	2940	3420
	4420	2200	2500	2500	2200	2480	2500	4405	2960	3450	2900	3370
Vista 3 Stage	4950	2200	2440	2500	2180	2400	2500	4610	2970	3460	2900	3370
full free lift	5550	2110	2310	2410	2070	2250	2380	4910	2900	3400	2830	3300
	6000	2020	2210	2310	1980	2150	2290	5210	2840	3320	2760	3220
								5810	2690	3170	2600	3060

## J2.2 – 3.5XN - Capacity Chart in kg @ 600mm Load Centre - Pneumatic Shaped Solid Tyres

Vista 2 Stage	3390	2000	2270	2270	2000	2250	2270	3200	2720	3130	2680	3110
limited free lift	3790	2000	2270	2270	2000	2250	2270	3600	2720	3130	2670	3100
	4330	2000	2270	2270	1990	2240	2270	4100	2720	3130	2660	3090
	4830	2000	2250	2270	1980	2210	2270	4600	2650	3090	2580	3010
Vista 2 Stage	3400	2000	2270	2270	2000	2260	2270	3205	2720	3130	2680	3110
full free lift	3800	2000	2270	2270	2000	2250	2270	3905	2720	3130	2660	3090
	4420	2000	2270	2270	1990	2240	2270	4405	2680	3130	2620	3050
Vista 3 Stage	4950	2000	2210	2270	1970	2170	2250	4610	2690	3130	2620	3050
full free lift	5550	1920	2100	2190	1870	2030	2150	4910	2630	3080	2560	2980
	6000	1830	2000	2100	1790	1940	2070	5210	2570	3010	2500	2920
								5810	2440	2870	2350	2760

The rated capacities shown are for masts in a vertical position on trucks equipped with standard or sideshift carriage and nominal length forks. Masts above the maximum fork heights shown in the mast table are classified as high lift and, depending on the tyre/tread configuration may require reduced capacity, restricted back tilt or wide tread.

## Branches

### VICTORIA

#### Melbourne - Springvale (Head Office)

📍 1574 Centre Rd  
Springvale, VIC, 3171  
☎ [03] 9547 8000

#### Melbourne - Truganina

📍 42-44 Jessica Way  
Truganina, VIC, 3029  
☎ [03] 9394 4090

### NEW SOUTH WALES

#### Sydney (State Office)

📍 219 Newton Rd  
Wetherill Park, NSW, 2164  
☎ [02] 8788 1777

#### Port Kembla

📍 20-26 Flinders Street  
Port Kembla, NSW, 2505  
☎ 13 22 54

### QUEENSLAND

#### Brisbane (State Office)

📍 11 Lombank Street  
Acacia Ridge, QLD, 4110  
☎ [07] 3373 5111

#### Rockhampton

📍 62 Glenmore Road  
Park Avenue, Rockhampton  
QLD 4701  
☎ [07] 4922 8874

#### Townsville

📍 39 Duckworth Street  
Garbutt, QLD, 4814  
☎ [07] 4778 2000

### SOUTH AUSTRALIA/ NORTHERN TERRITORY

#### Adelaide (State Office)

📍 18-22 Churchill Rd. Nth.  
Dry Creek, SA, 5094  
☎ [08] 8360 3444

### WESTERN AUSTRALIA

#### Perth (State Office)

📍 Unit 1, 1-9 Kurnall Road  
Welshpool, WA, 6106  
☎ [08] 9352 9200

#### Karratha

📍 Lot 3873-Pemberton Road  
Karratha, WA, 6714  
☎ 13 22 54

### TASMANIA

#### Spreyton

📍 87a Devonport Road  
Spreyton, TAS, 7310  
☎ [03] 6427 3966

## Service Centres

### VICTORIA

Bendigo  
Warrnambool  
Ballarat  
Shepparton  
Wondonga  
Mildura

### TASMANIA

Hobart  
Launceston  
Burnie

### NEW SOUTH WALES

Dubbo  
Griffith  
Tamworth  
Newcastle  
Wollongong  
Canberra  
Tumut  
Bathurst  
Wagga Wagga  
Albury  
Gosford  
Coffs Harbour

### QUEENSLAND

Rockhampton  
Mackay  
Cairns  
Gladstone  
Townsville  
Mt Isa  
Toowoomba  
Gold Coast  
Sunshine Coast

### SOUTH AUSTRALIA/NT

Riverland  
Darwin

### WESTERN AUSTRALIA

Margaret River



# 13 22 54

[www.adaptalift.com.au](http://www.adaptalift.com.au)