

COMBiLiFT

LIFTING INNOVATION

COMBi-SC

Straddle Carrier



The Cost Effective Solution For Handling
Containers & Oversized Loads

COMBi-SC

Straddle Carrier



Reduce your Operating Costs, Increase Storage Capacity and Improve Safety with the Combi-SC Straddle Carrier

The Cost Saving Solution

The Combi-SC range is the most economical handling solution for distribution, shipping and industries with heavy and oversized loads. Its manoeuvrability, light footprint and high customisation offer complete independence when moving containers and oversized loads.

The Combi-SC range does what it promises: it is a cost effective and flexible container handling solution which guarantees quick ROI even for companies with relatively low throughput levels.





Lighter Footprint

The Combi-SC's much lighter unladen weight, at only 17 ton compared to comparable heavy duty forklifts that can reach 80 ton, makes it extremely fuel efficient.

The low service weight and large puncture proof flotation tires greatly reduce ground pressure, enabling operation on poor and semi rough terrain, avoiding the need for costly investment on ground resurfacing or improvement.

Superior Safety

Safety is of paramount importance for Combilift when designing all its handling solutions and the Combi-SC is no exception. Its optimum centre of gravity, broad wheelbase and exceptional 3-wheel manoeuvrability mean maximum load stability.

The centrally located, ground accessible cabin is designed for operator safety and comfort with 360° visibility from the cab meaning they can transport loads in confidence.

The user interface is intuitive and all functions can be carried out from within the cab reducing the need for operatives to work at height, which ensures the highest levels of operator safety and productivity.



Reliable and Fuel Efficient

Unmatched reliability, fuel efficiency and much lighter service weight ensure you can maintain maximum levels of productivity.

All Combilift straddle carriers are designed to minimise service downtime. Its straightforward design incorporates standard components which are easy to source for extreme reliability and ease of maintenance wherever you are in the world.

Faster turnaround

The Combi-SC offers unbeatable turn around speed with safe stuffing/de-stuffing at ground level. It can lift, transport and set down 20', 30', 40' and 45' high cube containers, reefer and flat rack containers.

360° visibility from the driver position and 2 minute off-loading from trailer to ground mean faster loading times without the need for trailers waiting to be loaded.



Oversized Loads



Often, the material handling challenges you face can be specific to your operation. Combilift's approach to handling oversized or awkward loads are well respected and true to our philosophy, every Combi-SC is highly customisable and can be built to your exact requirements becoming the ideal solution to the material handling challenges you face.

Robust and reliable

The Combi-SC's robust build, its super elastic tyres, a lack of over sensitive electronic components and the ability to work on semi-rough terrain make it the ideal workhorse for any tough environment.

So contact Combilift and we will build you a bespoke carrier ideally suited for your needs which will save you money, increase productivity and much more.



Remote Control Option

Combilift offer a remote control option for the Combi-SC which offers safety and productivity benefits. Increased visibility and easier rigging alignment mean safer conditions. The need for a spotter/banksman in a confined area is eliminated increasing return on investment.



Effortless Double Stacking & Transport Under Low Doorways

The optional telescopic function enables effortless double stacking of containers whilst also being able to telescope down to manoeuvre and set down containers under low doorways.



Faster throughput with the Automatic Top-Lift Spreader

The optional automatic top lift spreader can be adjusted to handle any ISO containers from within the cab, reducing manual strain and protecting operators from the elements.

Used to grip and pick up the container by means of four twist locks which enables faster and safer throughput of 20 containers per hour.



Efficient Dock Loading

The Combi-SC has the unique ability to position a container flush with a loading bay door greatly improving loading times.



Safer Container Tipping

The Combi-SC can tilt containers at an angle of 75° for efficient and safe off-loading of containers of bulk materials such as foodstuffs, scrap material, minerals, plastic granules, chemical products and aggregates.



The same machine can invert containers for quick and safe loading of bulk.

SOLAS Compliant Weight Measurement System

Combilift has responded to the new *SOLAS Regulations* which came into force from 1st July 2016, by offering a fully compliant weight measurement system on the Straddle Carrier.

The regulations mean that the Verified Gross Mass (VGM) documentation will be required prior to loading cargo onto ships,

The new system allows the Straddle Carrier to weigh loads once, in real-time, to an accuracy of +/-1% effectively making it a mobile weighing system.

This system is much more efficient than a weighing bridge which must weigh the load multiple times, measuring the same tractor unit with load and without.

- Accurate to +/- 1%
- OIML compliant - Optional
- Rated to IP67
- Stainless steel load measuring pins
- 1 x Ruggedised cab mounted Tablet for data storage
- Combi-SC can be considered mobile weighing system within a given area with all the advantages of the Straddle Carrier
- Highly cost effective in comparison to fixed weighing system that cannot easily be relocated



4 Load weighing Pins



In-Cab Ruggedised Tablet



Interface Module

Load Stabiliser System

The retractable load bearing system which is unique to the Straddle Carrier, supports the suspended load, eliminating swing, greatly increasing safety.



Engineered for ease of transport

The Combi-SC is engineered for easy and cost effective transport, by trailer or container – making relocation of the machines an easy job.



STANDARD BUILD <i>*CUSTOMISATION AVAILABLE</i>		<i>Metric</i>		<i>Imperial</i>	
		<i>SC3</i>	<i>SC3T</i>	<i>SC3</i>	<i>SC3T</i>
	DESCRIPTION	Trailer to Ground	Telescopic 2 High Option	Trailer to Ground	Telescopic 2 High Option
1	Overall Length	8570mm		338"	
2	Overall Width *	4920mm		194"	
3	Overall Height *	5165mm	4925mm - 6725mm	203"	194"-265"
4	Ground Clearance Under Cab	275mm		11"	
5	Height Over Cab	2300mm		91"	
6	Track Front	3750mm		148"	
7	Wheelbase	5775mm		227"	
8	Width Load Area	3000mm		118"	
9	Height Load Area *	4600mm	4360mm - 6160mm	181"	172" - 243"
10	Turnig Radius	7250 mm		285"	
A	Capacity	20,000kg to 100,000kg			
B	Unladen Weight	16,950 kg	19,200 kg	37,370 lbs.	42,300 lbs.
C	Gradeability	5% Fully Loaded			
D	Maximum Ground Speed	10 km/h		6 mph	
E	John Deere 4045 Diesel	93kW		125 hp	
F	Electric's	12 Volt			
G	Tyres	4 x Super Elastic Soft Solid Tyres			
H	Standard Colour	Yellow & Grey			
I	Suspension Seat	KAB Model 116			
J	Remote Control	Optional			

SPECIFICATIONS

The specification left is for the standard Straddle Carrier model. The Combi-SC is highly customisable.

Contact the Combilift team with your requirements, and our engineers will provide you with the ideal and most cost effective material handling solution in the market.

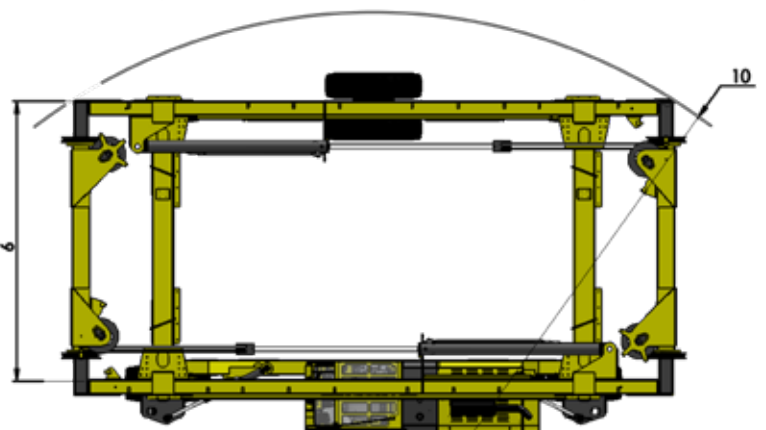
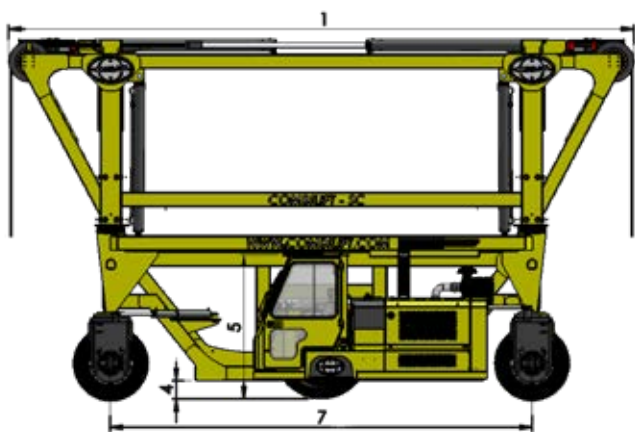
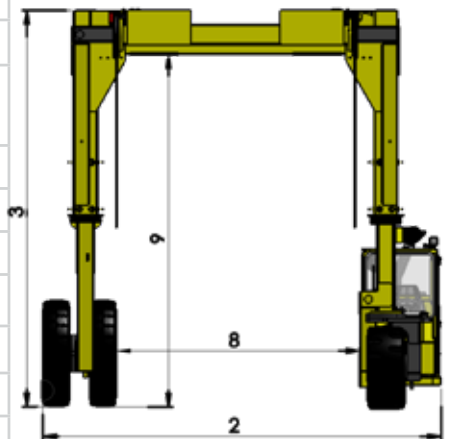

Features at a glance:

- Highly customisable.
- Low ground pressure when fully loaded
- Easy to service
- Reduced fuel/energy consumption
- Rough terrain & ramp friendly, works on compacted stone, bitumen and light concrete
- Exceptional 3-wheel maneuverability
- No brake maintenance
- Ergonomically designed /driver friendly cab
- Travels in/out of warehouse with ease
- Same Unit can lift 20', 30', 40', 45' Containers
- Side Shift Front & Rear
- 360 degree vision when load is lifted
- Soft Solid puncture proof tyres

Combilift HQ:

Co. Monaghan, Ireland
Tel: + 353 47 80500

Combilift USA:

Greensboro, NC 27406
Tel: 1877 266 2456

info@combilift.com

Swing Lift Compatible



Capacities up to 100,000 Kg



Distributed by: